

**Tower Crane
Grue à tour**

Turmdrehkran 50 K

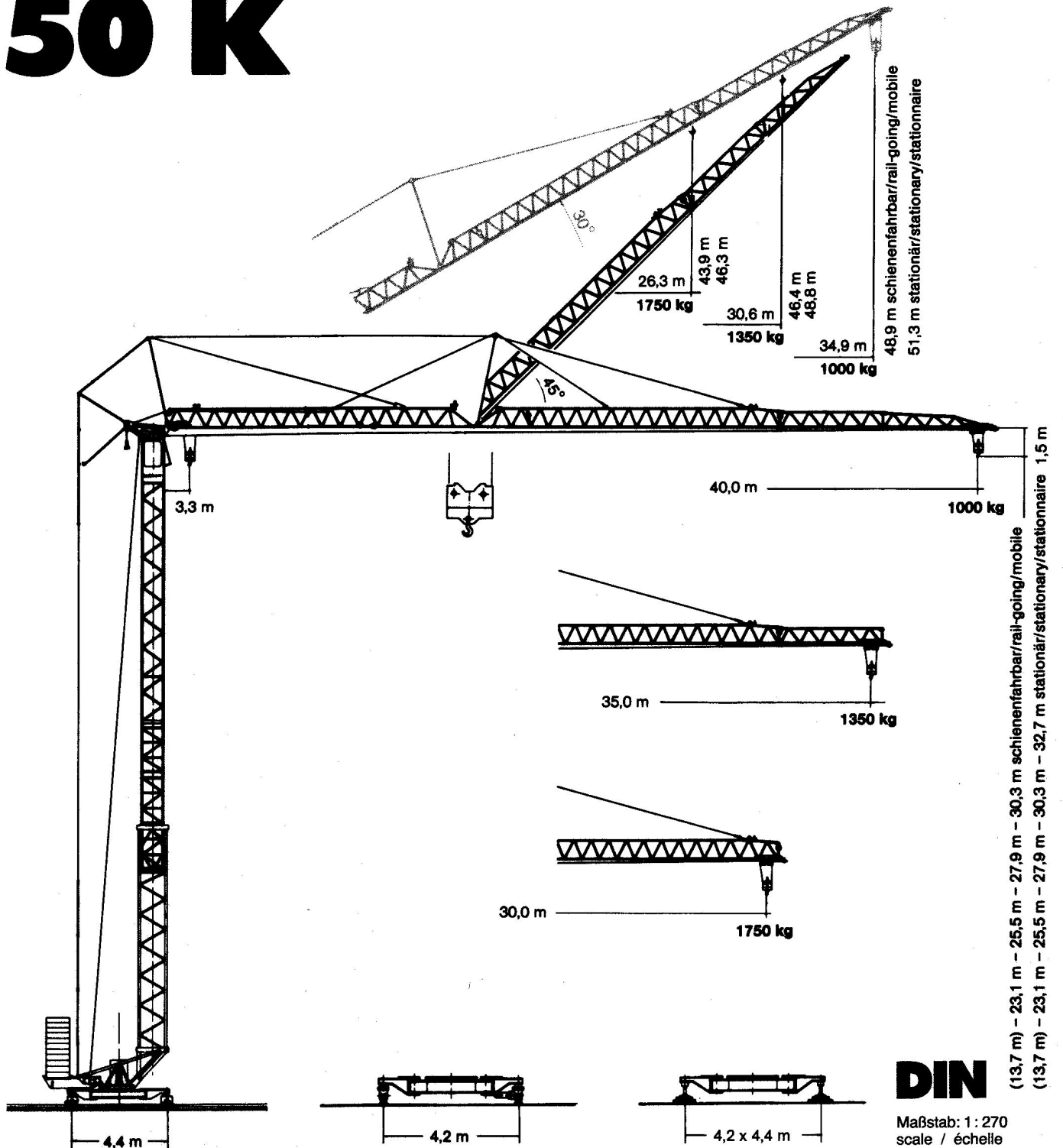

LIEBHERR

36,6 m (3 Turmstücke) Tower section
39,0 m (4 Turmstücke) Élément de mât

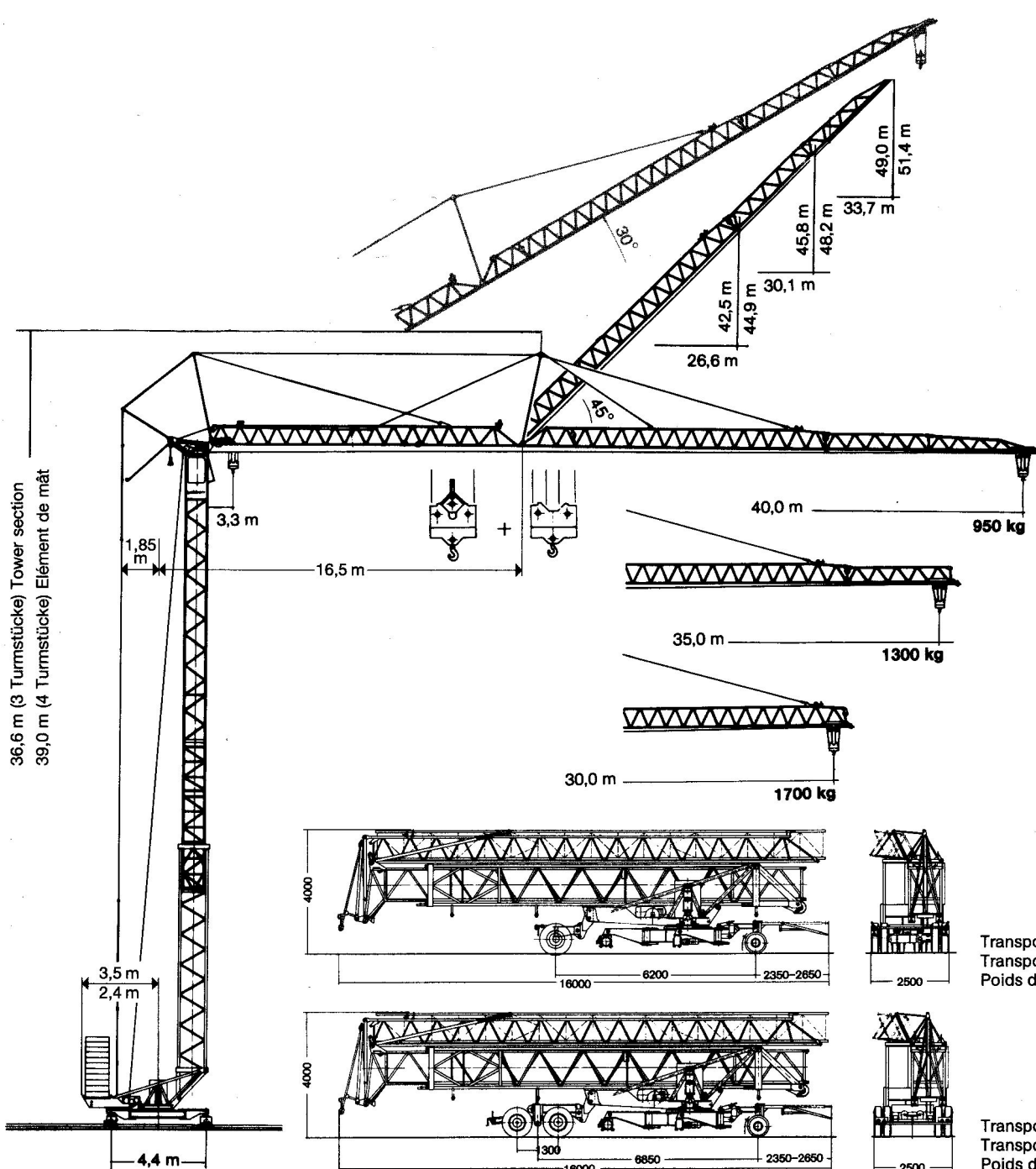

Transportgewicht ca. 17140 kg
Transport weight approx.
Poids de transport env.

Transportgewicht ca. 18800 kg
Transport weight approx.
Poids de transport env.

Transportgewicht ca. 18440 kg
Transport weight approx.
Poids de transport env.

Gewicht

Weight

Poids

Max. Eckkraft in Betrieb
Max. corner pressure in operation
Réaction maxi. par angle en service 250 kN*

Max. Eckkraft außer Betrieb
Max. corner pressure out of operation
Réaction maxi. par angle hors service 220 kN*

Gegengewicht ca. r = 3,5 m 20000 kg
Counter weight approx. r = 2,4 m 27500 kg
Contrepoids env.

Konstruktionsgewicht (max. Ausladung + Hakenhöhe) ca. 16700 kg
Dead weight (max. radius + hook height) approx. 16700 kg
Poids de la construction (max. portée + hauteur sous crochet) env.

* Umrechnung der Einheiten für Kräfte 1 kp ≈ 10 N; 10 kN ≈ 1 Mp./Conversion of the units for forces./Conversion des unités des forces.

50 K

Ausladung und Tragfähigkeit

Radius and capacity / Portée et charge

Auslegerlänge Length of jib Longueur de flèche m	max. kg m/kg	m/kg																				
		20,0	21,0	22,0	23,0	24,0	25,0	26,0	27,0	28,0	29,0	30,0	31,0	32,0	33,0	34,0	35,0	36,0	37,0	38,0	39,0	40,0
40,0	3,3-20,8 2300	2300	2270	2140	2030	1920	1830	1740	1660	1580	1520	1450	1390	1340	1290	1240	1190	1150	1100	1070	1035	1000
35,0	3,3-22,8 2300	2300	2300	2300	2270	2160	2050	1960	1870	1790	1710	1650	1570	1510	1460	1400	1350					
30,0	3,3-24,0 2300	2300	2300	2300	2300	2300	2190	2090	1990	1900	1830	1750										

m	max. kg m/kg	m/kg																				
		13,0	14,0	15,0	16,0	17,0	18,0	19,0	20,0	21,0	22,0	23,0	24,0	26,0	28,0	30,0	32,0	34,0	35,0	36,0	38,0	40,0
40,0	3,3-20,8 2250 -11,9 4500	4050	3680	3370	3100	2870	2670	2500	2340	2200	2070	1960	1860	1680	1530	1390	1280	1180	1140	1100	1020	950
35,0	3,3-22,8 2250 -13,1 4500	4500	4130	3780	3490	3230	3010	2810	2640	2480	2340	2220	2100	1900	1730	1590	1460	1350	1300			
30,0	3,3-23,8 2250 -13,9 4500	4500	4400	4030	3720	3450	3210	3000	2820	2650	2500	2370	2250	2030	1850	1700						

m	max. kg m/kg	Auslegersteilstellung 30° Elevated jib 30° Flèche inclinée 30° m/kg																				
		16,0	17,0	18,0	19,0	20,0	21,0	22,0	23,0	24,0	25,0	26,3	27,0	28,0	29,0	30,0	30,6	31,0	32,0	33,0	34,0	34,9
40,0	3,1-18,3 2300	2300	2300	2300	2190	2050	1930	1820	1720	1630	1550	1450	1400	1340	1280	1220	1190	1170	1120	1080	1040	1000
35,0	3,1-20,0 2300	2300	2300	2300	2300	2300	2170	2050	1940	1840	1750	1640	1580	1510	1450	1390	1350					
30,0	3,1-21,1 2300	2300	2300	2300	2300	2300	2190	2070	1960	1860	1750											

Geschwindigkeiten Speeds / Vitesses

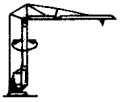
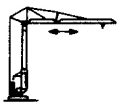
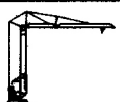
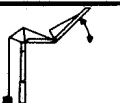
	U/min 0 - 0,8 sl./min tr./min	3,0 kW
	20,0 / 40,0 m/min	1,5 / 2,2 kW
	25,0 m/min	2 x 1,5 kW
	0-45° ca. 60 sec.	3,0 kW

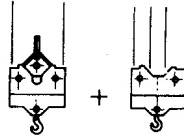
Hubwerk Hoist unit Mécanisme de levage	Stufe Step Cran	kg	m/min
15,0 kW 	1	2300	6,0
	2	2300	27,0
	3	1600	50,0
	1	2250 4500	6,0 3,0
	2	2250 4500	27,0 13,5
	3	1600 3200	50,0 25,0

Leitungsquerschnitt bei 380 V
Cross section of cable
Section de câble à

Betriebsspannung 380 V
Operating voltage
Tension de service

Technische Kenngröße nach BGL

Technical nominal size according to the construction machinery list (BGL)
Grandeur caractéristique suivant le barème d'emploi des appareils (BGL)

bis 99,0 m
up to
jusqu'à

Frequenz 50 Hz
Frequency
Fréquence

Anschlußwert 28,0 kVA
Power requirement
Puissance requise



2108-0050

Technische Daten - Technical data Caractéristiques techniques

Aufstellvorgang

Erection procedure

Déroulement de montage

Ballastierausladung 5,0 m

Ballasting radius 5,0 m

Portée pour dispositif de lestage 5,0 m

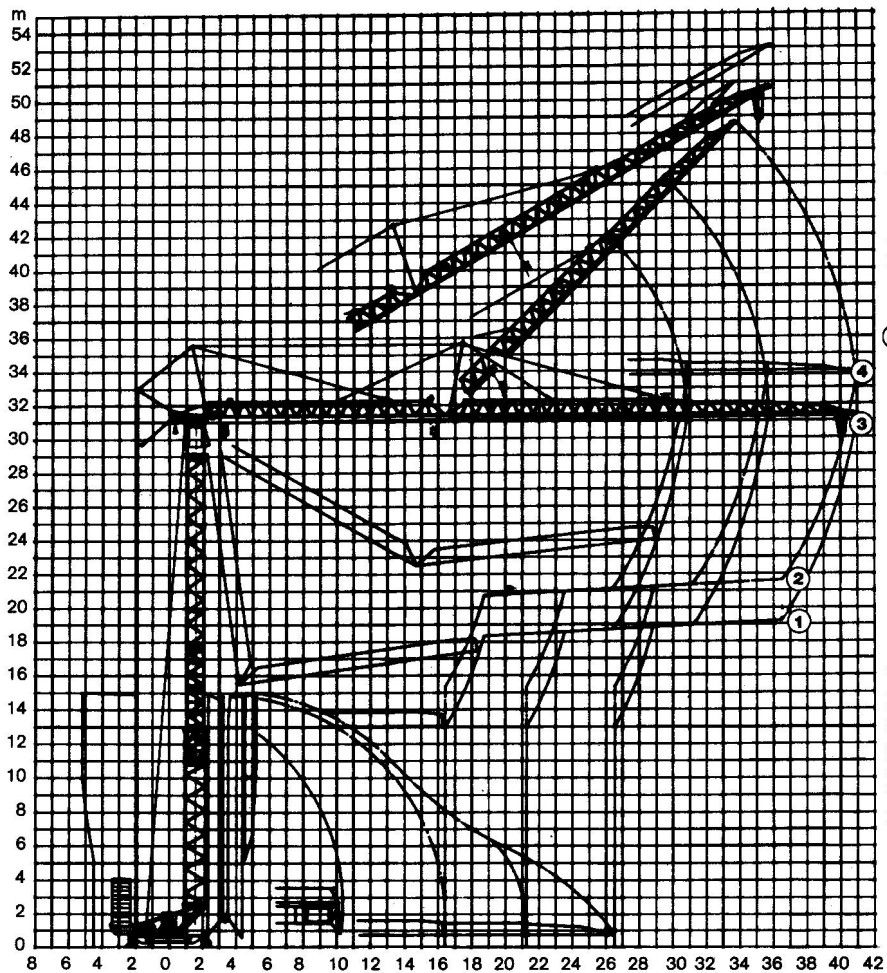





- ④ stationär
4 Turmstücke
stationary
4 tower sections
stationnaire
4 éléments de mât
- ③ schienenfahrbar
3 Turmstücke
rail-going
3 tower sections
mobile
3 éléments de mât
- ② stationär
ohne Turmstück
stationary
without tower
section
stationnaire
sans éléments
de mât
- ① schienenfahrbar
ohne Turmstück
rail-going
without tower
section
mobile
sans éléments
de mât

Kolli-Liste

Packing List

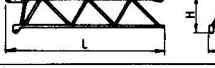
Liste de colisage

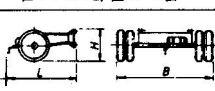
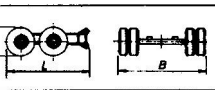
Pos. Item Rep.	Anz. Qty. Qté		L (m)	B (m)	H (m)	kg	
1	3	Turmstück (ohne Turmauflage) Tower section without tower support Élément de mât sans support de mât		2,50	1,10	1,10	450
2	1	Turmstück (mit Turmauflage) Tower section with tower support Élément de mât avec support de mât		2,50	1,10	1,10	550
3	1	Ausleger-Verlängerung 30,0 m – 35,0 m Jib extension Rallonge de la flèche		5,00	1,02	0,80	185
4	1	Ausleger-Verlängerung 35,0 m – 40,0 m Jib extension Rallonge de la flèche		5,10	1,02	0,70	130
5	1	Transportachse vorne Tra 100 KY 1 Road transport axle front Essieux de transport avant		3,00	1,13	0,97	680
6	1	Transportachse hinten Tra 120 GY 1 Road transport axle behind Essieux de transport arrière		1,90	2,50	1,05	1200
7	1	Transportachse Tra 200 GZ 3 Road transport axle Essieux de transport		3,10	2,50	1,10	2500
8	1	Kiste mit Seilen und Kleinteilen Case with ropes and small parts Caisse avec câbles et pièces détachées		1,00	0,80	1,00	450

Datenblatt Nr. 120 P – 2426 H 1 B 3 DIN 15018 und OENORM T 3 • 04.94

Data sheet

Feuille de caractéristiques

Konstruktionsänderungen vorbehalten!
Subject to alterations!
Sous réserves de modifications!

Printed in Germany

Nehmen Sie Kontakt auf mit
Contact

Mettez-vous en rapport avec

LIEBHERR-WERK BIBERACH GMBH, Postfach 1663, D-88396 Biberach an der Riß

☎ (07351) 41-0, Fax (07351) 41225, Tx 71 802