

**Tower Crane
Grue à tour**

Turmdrehkran 20 SE

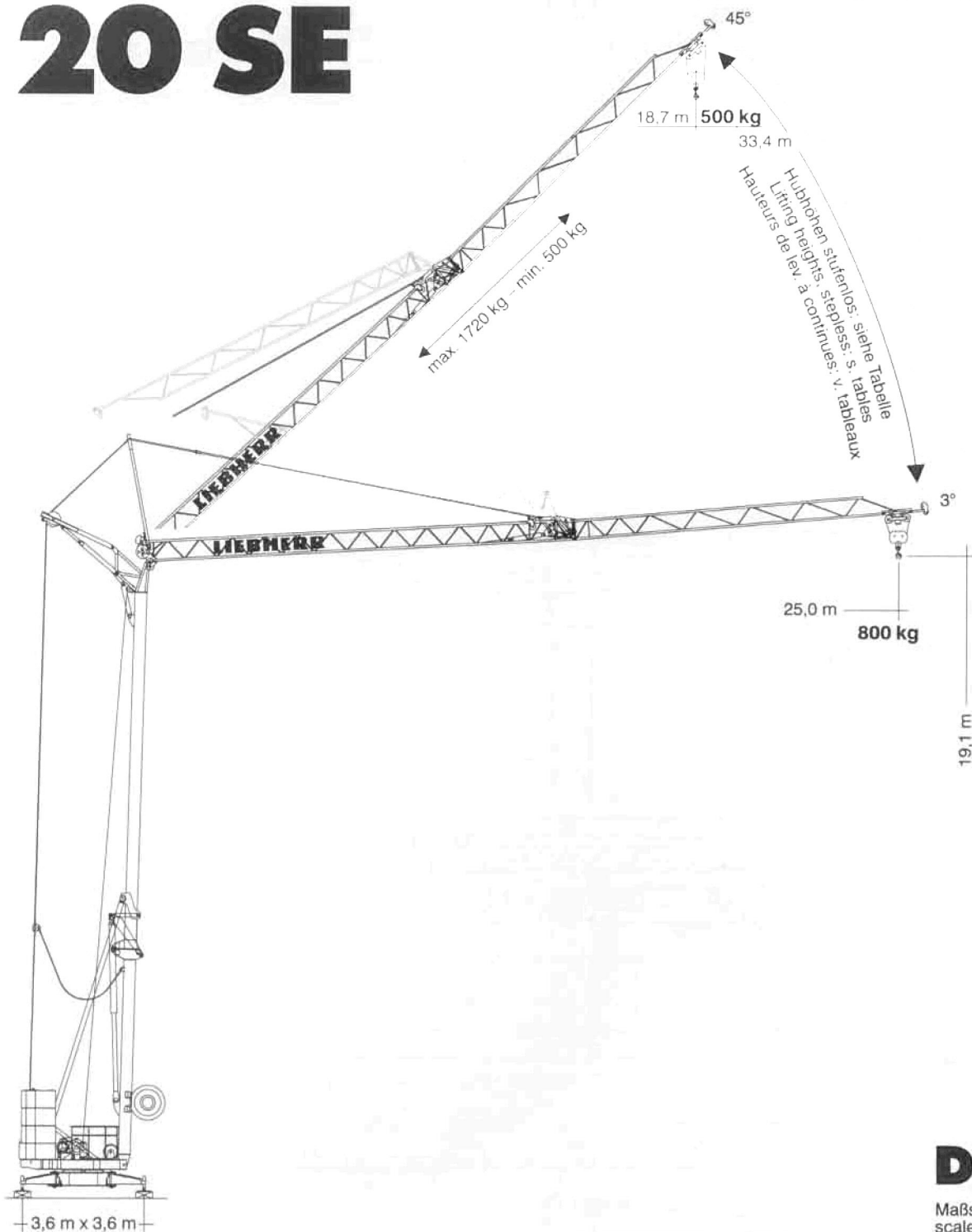

LIEBHERR

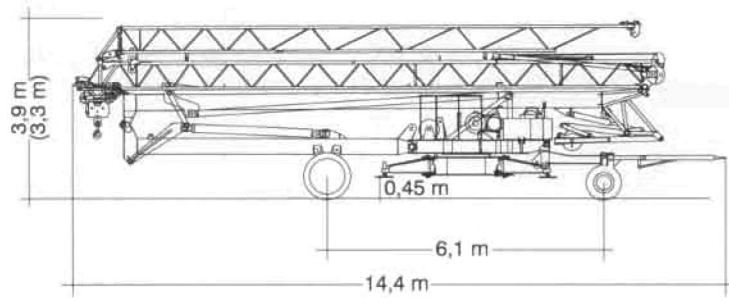
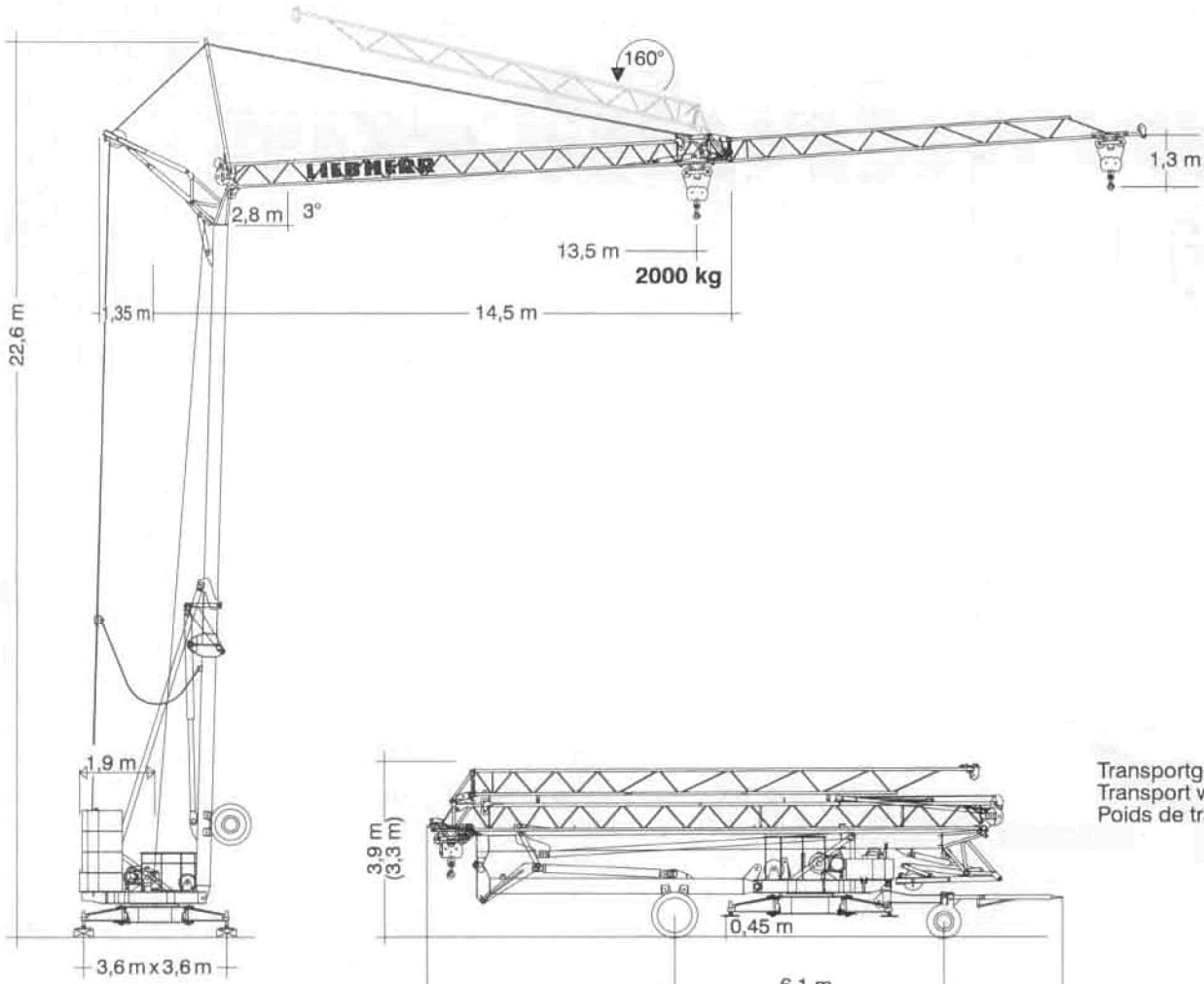

Transportgewicht ca. 17550 kg
 Transport weight approx.
 Poids de transport env.

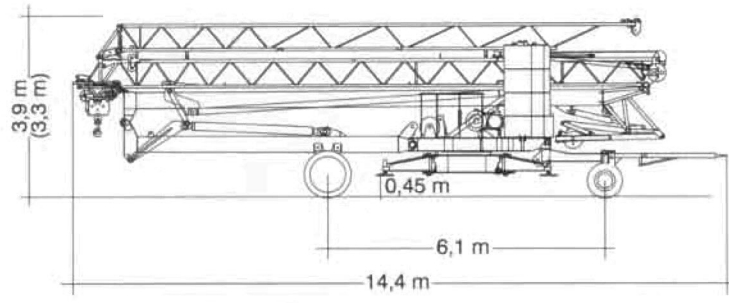

Transportgewicht ca. 22800 kg
 Transport weight approx.
 Poids de transport env.

Gewicht

Weight

Poids

Gegengewicht Counterweight Contrepoids	$r = 1,9 \text{ m}$	11750 kg	Konstruktionsgewicht ca. Dead weight approx. Poids de la construction env.	9000 kg
--	---------------------	----------	--	---------

20 SE

Ausladung und Tragfähigkeit

Radius and capacity

Portée et charge

Auslegerlänge Length of jib Longueur de flèche m	max. kg m / kg	m/kg																
		9,0	10,0	11,0	12,0	13,0	14,0	15,0	16,0	17,0	18,0	19,0	20,0	21,0	22,0	23,0	24,0	25,0
25,0	2,8-12,2 2000	2000	2000	2000	2000	1850	1680	1540	1420	1310	1220	1140	1070	1000	945	890	840	800

Auslegersteilstellung

Steep angle positions





En position relevée

	① Hakenhöhe (m) hoisting height Hauteur sous crochet	② Ausladung (m) radius Portée	③ Tragfähigkeit (kg) Capacity Charge	(Zwischenwerte siehe Betriebsanweisung) (Values in between see instruction manual) (Valeurs intermédiaires voir manues d'instructions)				
	10°	15°	20°	25°	30°	35°	40°	45°
①	21,6	23,5	25,4	27,2	29,0	30,7	32,3	33,4
25,0 ②	2,7-11,8 -24,7	2,7-15,3 -24,3	2,7-19,1 -23,6	2,6 - 22,9	2,6 - 21,9	2,6 - 20,9	2,5 - 19,6	2,5 - 18,8
③	-1720-650	-1270-700	-1000-750	820	700	600	530	500

Geschwindigkeiten

Speeds

Vitesses

	U/min 0 ↔ 0,9 sl./min tr./min	1,5 kW, EDC	Hubwerk Hoist unit Mécanisme de levage 8,0 kW 	Stufe Step Cran	kg	m/min
	18,0 / 36,0 m/min	0,95 / 1,4 kW 1,9 / 2,8 kW *		1	2000	5,0
	ca. 160°/min.	4,0 kW		2	2000	20,0
	ca. 10°/min.	4,0 kW		3	1000	40,0

* Ausführung mit Auslegersteilstellung / Version with steep-angle jib position /
Version avec flèche relevée

Leitungsquerschnitt bei 380 V bis 68,0 m 4 x 6 mm²
Cross section of cable up to
Section de câble à jusqu'à

Betriebsspannung 380 V
Operating voltage
Tension de service

Frequenz 50 Hz
Frequency
Fréquence

Anschlußwert
Power requirement
Puissance requise

16,0 kVA

Technische Kenngröße nach BGL

Technical nominal size according to the construction machinery list (BGL)
Grandeur caractéristique suivant le barème d'emploi des appareils (BGL)



2105-0020

Technische Daten - Technical data

Caractéristiques techniques

Aufstellvorgang

Erection procedure

Déroulement de montage

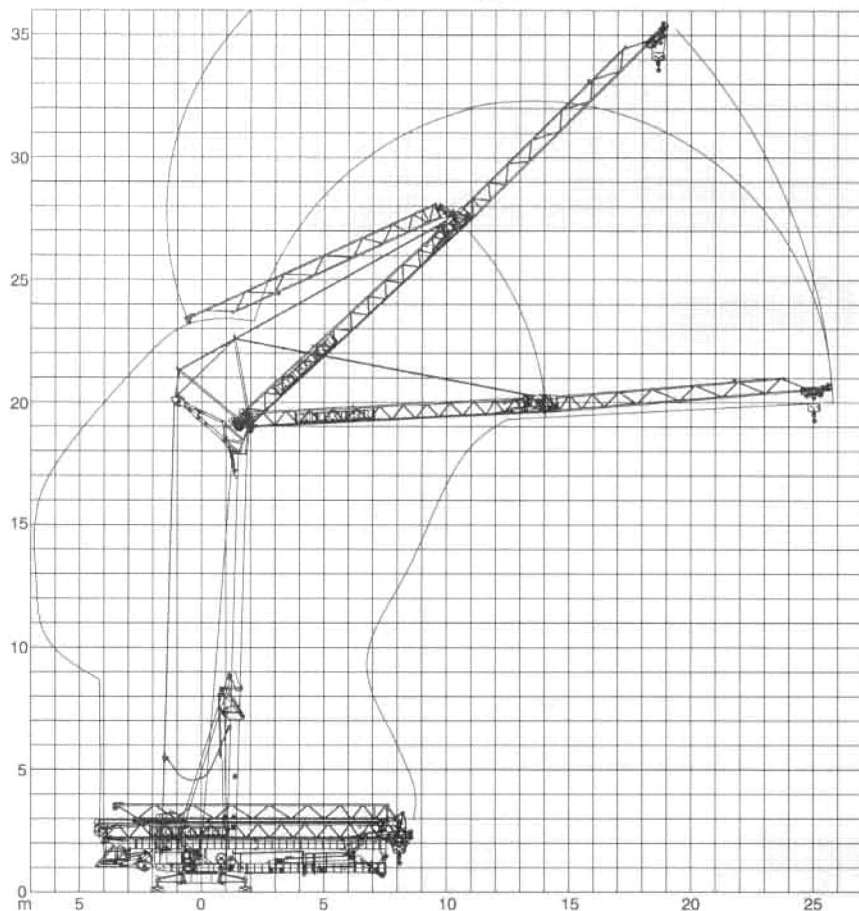

Kolli-Liste

Packing List

Liste de colisage

Pos. Item Rep.	Anz. Qty.				L (m)	B (m)	H (m)	kg	
1	1	Transportachse vorne, 20 SE-Adapter	Tra 100 KY 1			4,30	1,25	1,31	750
		Road transport axle front, 20 SE adapter	und/and/et KY 2			4,30	1,25	1,31	850
		Essieux de transport avant, pièce d'adapt. 20 SE	Tra 100 KY 6						
2	1	Transportachse hinten, 20 SE-Adapter	Tra 120 GY 1			1,60	2,50	1,20	1000
		Road transport axle behind, 20 SE adapter	und/and/et GY 1 A						
		Essieux de transport arrière, pièce d'adapt. 20 SE							
3	1	Transportachse vorne m. Zwischenadapter	Tra 100 KY 1			4,30	1,25	1,31	950
		Road transport axle front w. adapter	und/and/et KY 2			4,30	1,25	1,31	1050
		Essieux de transport avant a. pièce d'adapt.	Tra 100 KY 6						
4	1	Transportachse hinten m. Zwischenadapter	Tra 120 GY 1			1,75	2,50	1,25	1200
		Road transport axle behind w. adapter	und/and/et GY 1 A						
		Essieux de transport arrière a. pièce d'adapt.							
5	1	Transportachse	Tra 200 GZ 1			3,10	2,50	1,40	2700
		Road transport axle							
		Essieux de transport							

Datenblatt Nr. 120 P - 3311 H1 B3 DIN 15018 • BGL 2105-0020 /

FEM (Section 1) Krangruppe A3 und OENORM T3 • 07.95

Data sheet

Feuille de caractéristiques

Konstruktionsänderungen vorbehalten!
Subject to alterations!
Sous réserves de modifications!

Printed in Germany

Nehmen Sie Kontakt auf mit

Please contact

Mettez-vous en rapport avec

LIEBHERR-WERK BIBERACH GMBH, Postfach 1663, D-88396 Biberach an der Riß

☎ (07351) 41-0, Fax (07351) 41225